

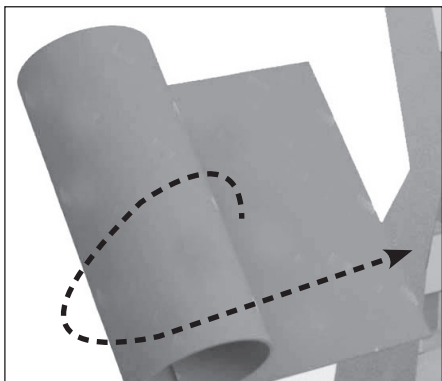

Isolamento acustico dei tubi di scarico / Pipe insulation installation Installierung der Rohr-Schallisolation / Isolation acoustique

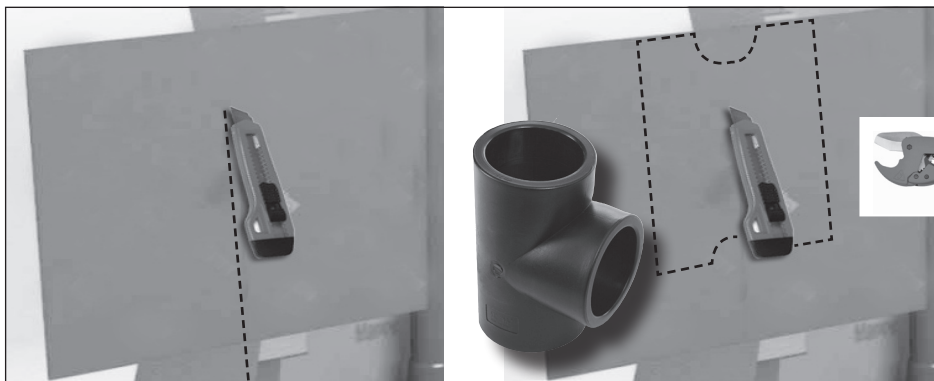

1 Srotola / Unroll / Abrollen / Dérouler



2 Tagliare con cutter o taglierino: facilmente sagomabile anche con tagli curvi (per connettori) / Cut with cutter or pipes cutter. Easy to cut curved for connecting pipe / Mit einem Messer oder Stanlymesser zuschneiden. Runde Teile sind einfach zuzuschneiden / Couper avec cutter ou coupe-tubes. Facile à couper sur le tubes de jonction

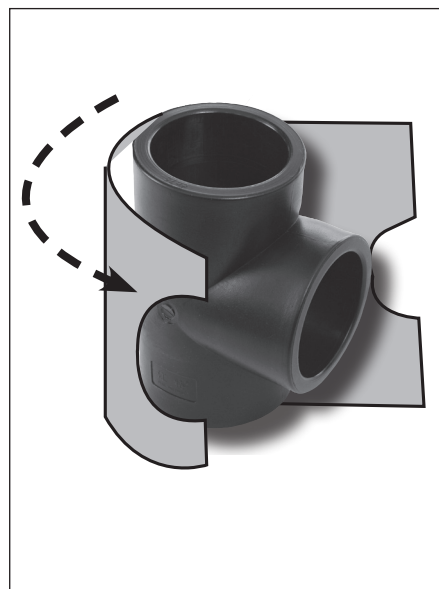
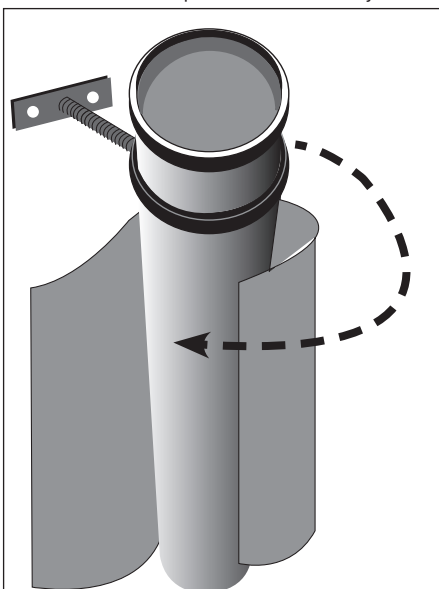
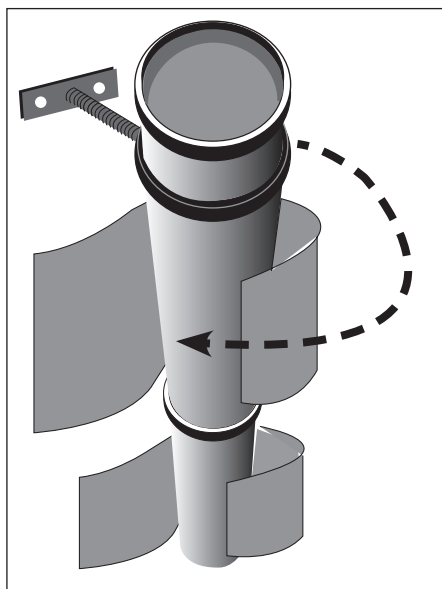

3 Ricoprire il tubo con il lato in PU verso l'interno / Wrap around the pipe with PU foam inside
Umwickeln Sie das Rohr mit der PU-Schaumseite innenlegend / Enroulez-le autour du tuyau avec de la mousse PU à l'intérieur

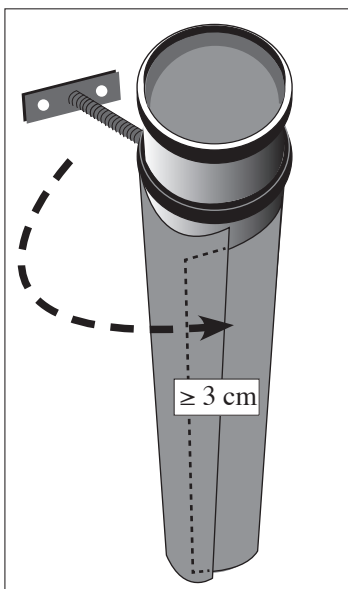

4 Sovrapporre senza lasciare spazi / Overlap taking care not to leave gaps / Bei der Umwicklung auf eine lückenlose Überlappung achten / Lors du recouvrement ne pas laisser d'espaces, faire chevaucher le matériel

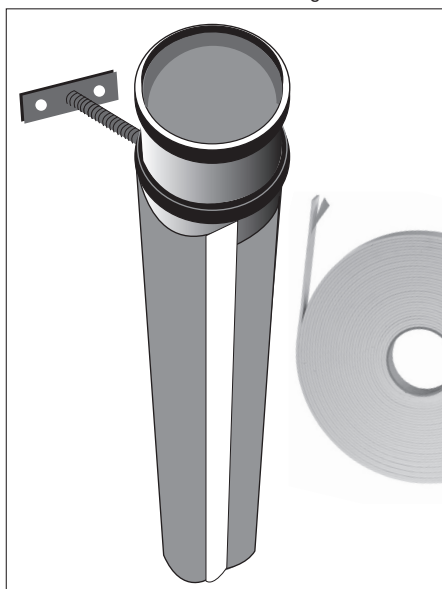

5 Sigillare la chiusura verticale con una guarnizione in PE / Seal the vertical side using PE Gaskets / Dichten Sie die vertikale Fuge mit einen PE Dichtungsbund ab / Sceller le côté vertical en utilisant des joints PE

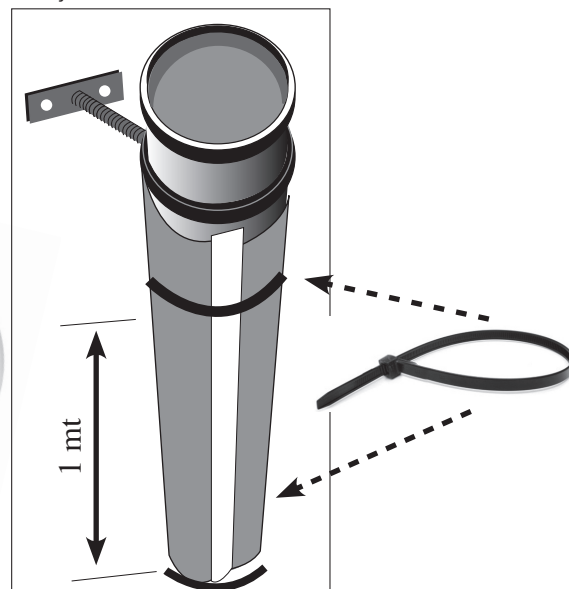

6 Fissare infine con fascette, lasciando uno spazio di circa 1 mt / Finally fix with cable ties. Correct applications of ties is 1 meter / Zum Schluß mit Kabelbinder fixieren / Der richtige Abstand der Kabelbinder beträgt 1meter / Enfin fixer avec des colliers de serrage. L'application correcte de liens est de 1 mètre



These data contribute to a **general description** of the product and the pictures are for illustration only. Each product is unique, it has high performance characteristics and installation specifications. It is therefore the user's sole responsibility to ensure that the product and its installation are suitable for specific application and in accordance with current legislation.

MCDEPTU12IN00000 REV.00 del 3/07/2012

